



Fuyang Cheer Machine&Hardware Co.,Ltd

Web: www.cheersonic.com

E-mail: cheerfree@hotmail.com

Tel: +86 0571 63372511 Fax: +86 0571 63373831

Mobile: 13588732518 MSN: cheerfree@hotmail.com

Type	Model	Fr(KHz)	Kp%/Kt%	C(pF)
Ultrasonic Cleaner	CFCC-20*7.8*3	84.5±1	≥40	800±10%
	CFCC-20*7.8*4	84.5±1	≥40	750±10%
	CFCC-30*10*5	55±1	≥40	1200±10%
	CFCC-35*15*5	45±1	≥40	1750±10%
	CFCC-35*15*5.5	45±1	≥40	1700±10%
	CFCC-38*13*6.35	43±1	≥43	1750±10%
	CFCC-38*15*5	45.5±1	≥42	1850±10%
	CFCC-15*6*3	106±1	≥40	620±10%
	CFCC-20*6*3	89±1	≥42	1200±10%
	CFCC-25*10*4	64±1	≥42	1250±10%
	CFCC-30*10*5	56±1	≥42	1750±10%
	CFCC-35*15*5.5	44±1	≥40	2050±10%
	CFCC-38*15*5	44±1	≥40	2000±10%
	CFCC-38*14.5*7.5	42.5±1	≥42	1750±10%
	CFCC-38*15*5	42±1	≥42	2500±10%
	CFCC-40*16*5	40±1	≥42	2700±10%
	CFCC-45*15*5	38±1	≥43	3600±10%
	CFCC-50*16*5	35±1	≥44	4600±10%
	CFCC-35*15*5	45.5±1	≥40	1430±10%
	CFCC-38*15*5	43±1	≥40	1740±10%
	CFCC-40*16*5	40.5±1	≥40	1920±10%
	CFCC-45*15*5	39±1	≥40	2570±10%
	CFCC-50*16*5	35.5±1	≥44	3200±10%
	CFCC-30*5.5-W	73±0.5	≥55	1450±10%
	CFCC-37.2*6.35-W	59±0.5	≥60	2100±10%
	CFCC-45*3.0-S	50±0.5	≥55	7000±10%
	CFCC-50*2.7-S	45.5±0.5	≥55	9200±10%
	CFCC-50*3.0-S	45.5±0.5	≥55	8600±10%
CFCC-50*5.0-S	45.5±0.5	≥58	5200±10%	
CFCC-50*6.5-S	75.5±0.5	≥55	1000±10%	
Ultrasonic Welder	CFCW-13*5*2.3	125±1	≥40	640±10%
	CFCW-40*16*6	40±1	≥40	2450±10%
	CFCW-50*16*6	35±1	≥42	3600±10%

	CFCW-50*20*5	32±1	≥40	4400±10%
	CFCW-50*20*6	32±1	≥40	3700±10%
	CFCW-50*20*7	32±1	≥40	3250±10%
	CFCW-55*25*7	27.5±1	≥40	3300±10%
	CFCW-70*33*9	21.3±1	≥40	4200±10%
	CFCW-50*16*6	35.5±1	≥42	2670±10%
	CFCW-50*16*6.5	35.5±1	≥42	2465±10%
	CFCW-50*16*8	35.5±1	≥42	2000±10%
	CFCW-50*17*6.5	34.8±1	≥42	2400±10%
	CFCW-50*20*7	32.5±1	≥40	2150±10%
	CFCW-50*20*8	32.5±1	≥40	1870±10%
	CFCW-55*25*7	28.5±1	≥40	2440±10%
	CFCW-60*30*10	35.5±1	≥42	1930±10%
	CFCW-70*33*9	21.8±1	≥42	3030±10%
Ultrasonic Atomizer	CFCA-20*1000-W	1000±30	≥40	1500±10%
	CFCA-20*1000-S	1000±30	≥40	1800±10%
	CFCA-25*1000-W	1000±30	≥40	2700±10%
	CFCA-25*1000-S	1000±30	≥40	2900±10%
	CFCA-28*1000-W	1000±30	≥40	2900±10%
	CFCA-28*1000-S	1000±30	≥40	3400±10%

CFCC-35*15*5-W

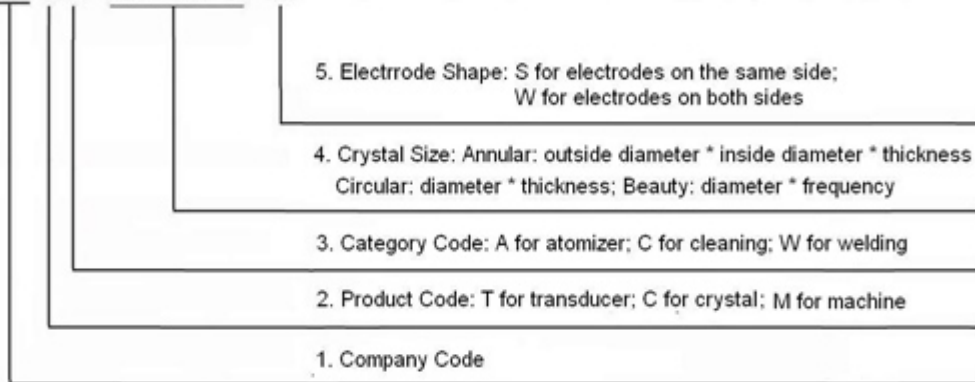

CFCC-35*15*5

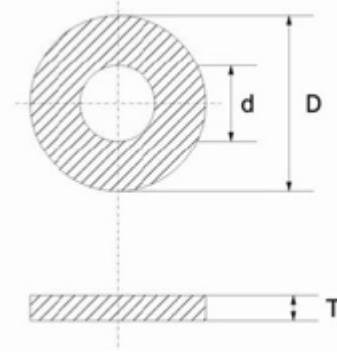

ELECTRICAL SPECIFICATION		
Item	Unit	Parameter
Capacity	pF	2050±10%
Dissipation factor	tg δ	≤0.5%
Frequency	KHz	44±1
Resonant impedance	Ω	≤15
Conversion efficiency	Kr/Kt%	≥40
Size(D×d×T)	mm	35×15×5

CFCC-25*1000-S

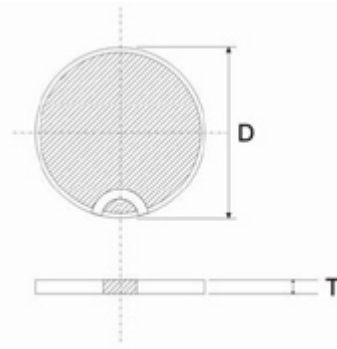

ELECTRICAL SPECIFICATION		
Item	Unit	Parameter
Capacity	pF	2750±10%
Dissipation factor	tg δ	≤0.4%
Frequency	KHz	1000±1
Resonant impedance	Ω	≤5
Conversion efficiency	Kr/Kt%	≥40
Size(D×T)	mm	25×2

CFCC-20*1000-W

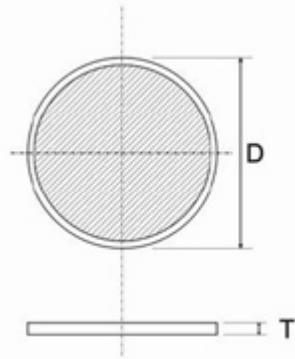

ELECTRICAL SPECIFICATION		
Item	Unit	Parameter
Capacity	pF	1400±10%
Dissipation factor	tg δ	≤0.4%
Frequency	KHz	1000±30
Resonant impedance	Ω	≤3
Conversion efficiency	Kr/Kt%	≥40
Size(D×T)	mm	20×1.2

CFCC-50*2.7-S

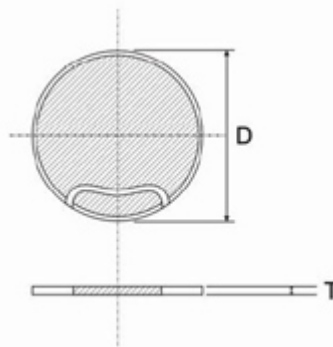

ELECTRICAL SPECIFICATION		
Item	Unit	Parameter
Capacity	pF	8000±10%
Dissipation factor	tg δ	≤0.4%
Frequency	KHz	45.5±1
Resonant impedance	Ω	≤8
Conversion efficiency	Kr/Kt%	≥55
Size(D×T)	mm	50×2.7